

Topview

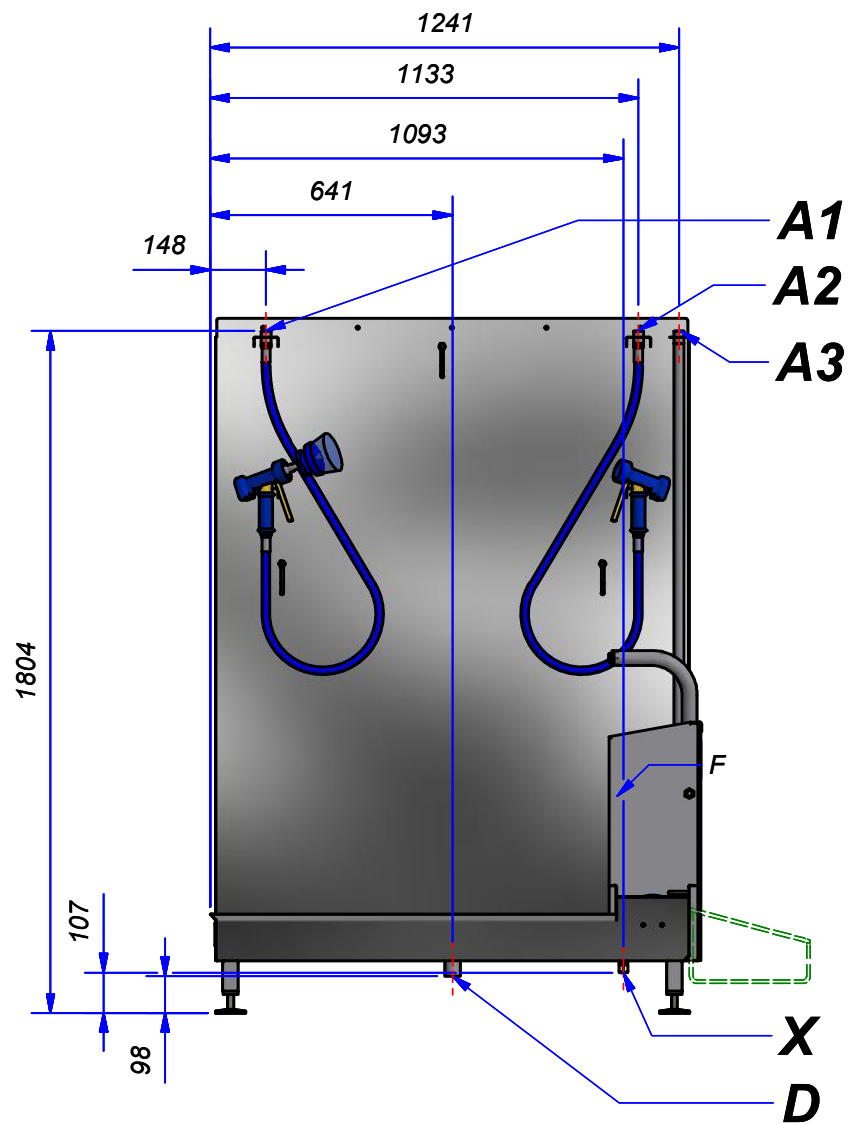

Frontview

Drainage standard opened at delivery

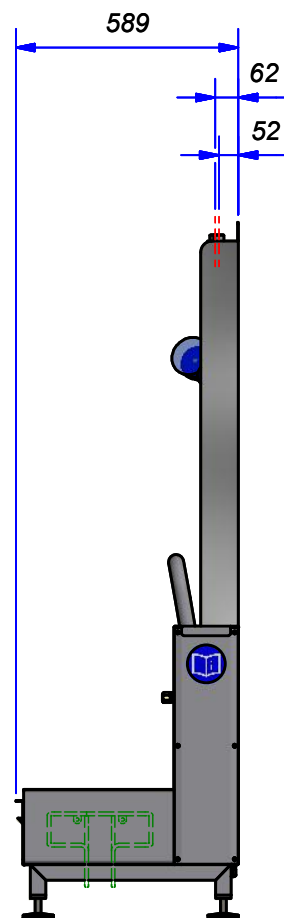

Sideview

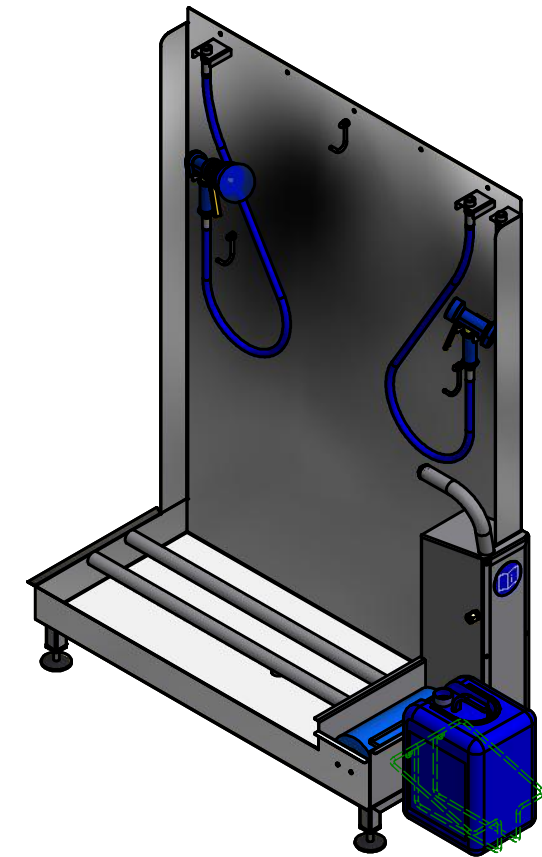

Green line: Optional

Jerrycan holder

Connection values

A	Cold water in	(3x) 1/2" BSP Female
D	Drainage	Ø40 mm
F	Chemical in	
X	Electrics	230 V / 50 Hz (1 ph + E + 0)
	Total power	0,2 kW
	Security	16 A
	Simultaneous value	100 %
	Connection	Schuko plug

Transport details

Packing method	Pallet with box
Packed dimensions	
Packed weight	
Weight	

The displayed jerrycan is not part of standard delivery

Title  
Lay out SWP-1000 EZW

Article number 78000351	Drawing number 1503000556	Revision	Material AISI 304 (1.4301)	CE
		Projection 	Date 12-2-2015	
Handelstraat 21 5831 AV Boxmeer tel. : +31 (0)485 516969 fax.: +31 (0)485 514022 www.elpress.com		THIS DRAWING IS PROPERTY OF ELPRESS BV. IT IS A CONFIDENTIAL DOCUMENT AND MAY NOT COPIED, USED OR PUBLISHED WITHOUT WRITTEN PERMISSION		