

A-A (1:5)

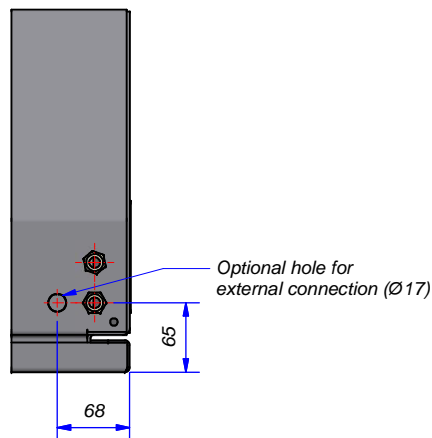

Side view

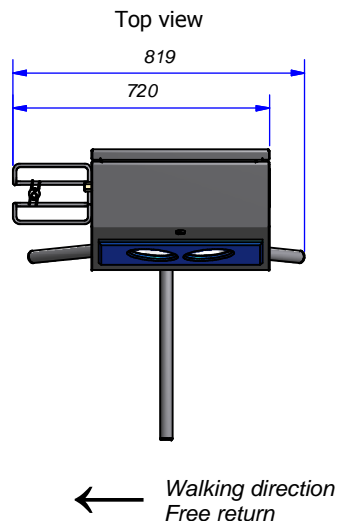
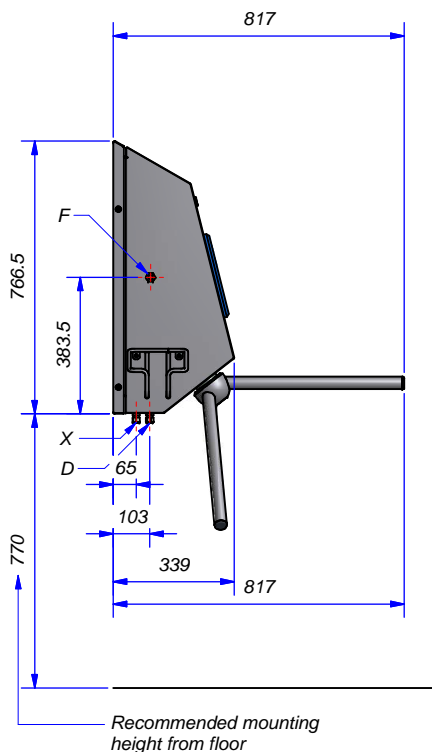

Front view

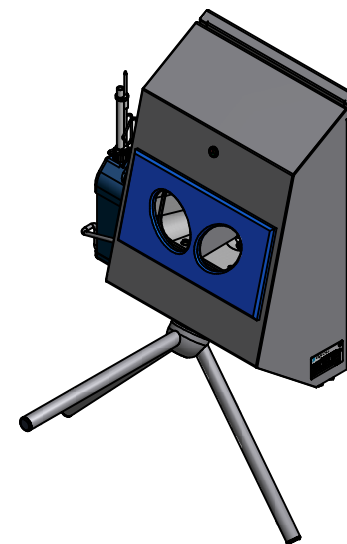
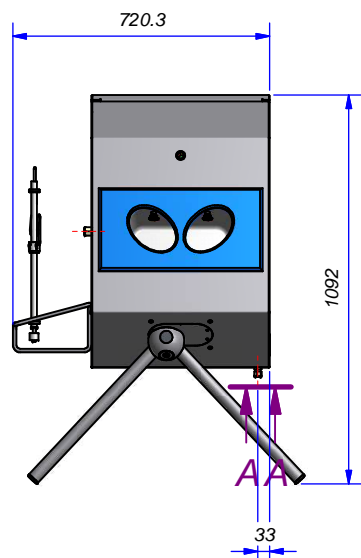

Connection values

D - Drainage	Ø10 mm
F - Chemical suction pipe	
X - Electrics	230 V / 50 Hz (3 ph + E + 0)
Total power	0.1 kW
Security	16 A
Simultaneous value	100 %
Connection	CEE-shape electrical outlet (5-pole)

Transport details

Packing method	Pallet with box
Packed dimensions	120 x 80 x 80 cm (l x b x h)
Packed weight	86 kg
Weight	50 kg

*The displayed jerrycan (5 L) is not part of standard delivery

Title Lay out HDT-WM-R		Customer		
Article no. 83201000	Drawing no. 1303004018	Drawn by EvdH		
 Elpress Cleaning Systems www.elpress.com	Handelstraat 21 NL - 5831 AV Boxmeer The Netherlands tel.: +31 (0)485 516969 fax.: +31 (0)485 514022	Projection 	Date 18-10-2013	Rev.
	THIS DRAWING IS PROPERTY OF ELPRESS BV. IT IS A CONFIDENTIAL DOCUMENT AND MAY NOT COPIED, USED OR PUBLISHED WITHOUT WRITTEN PERMISSION.			