

Top view

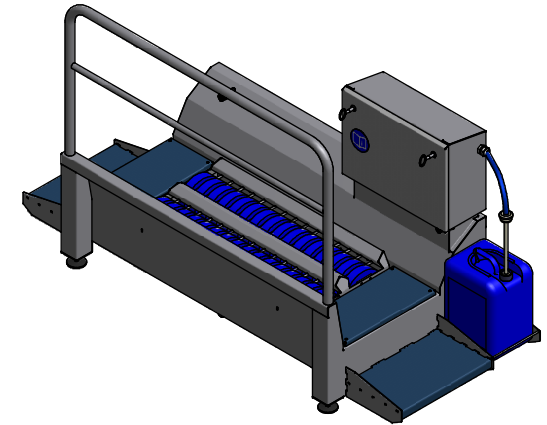

Side view

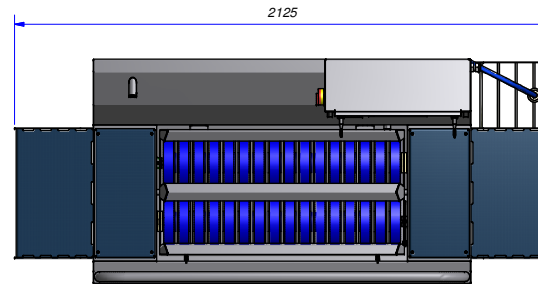
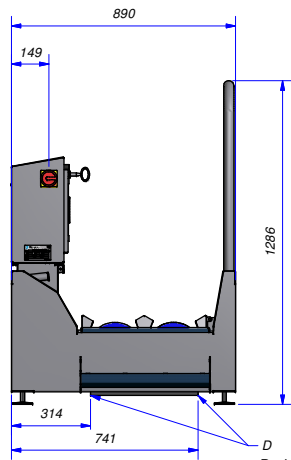

Drainage standard on both sides opened at delivery

Front view

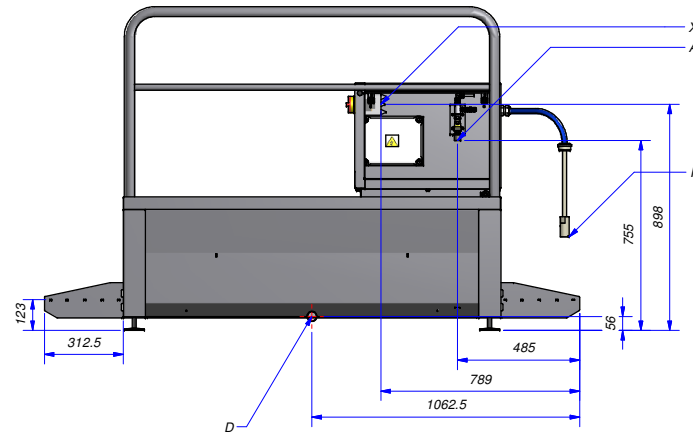



**Connection values**

|   |                    |                                      |
|---|--------------------|--------------------------------------|
| A | Water in           | 3/4" BSP Male                        |
| D | Drainage           | Ø40 mm                               |
| F | Chemical in        |                                      |
| X | Electrics          | 400 V / 50 Hz (3 ph + E + 0)         |
|   | Total power        | 1 kW                                 |
|   | Security           | 16 A                                 |
|   | Simultaneous value | 100 %                                |
|   | Connection         | CEE-shape electrical outlet (5-pole) |

**Transport details**

|                   |                                 |
|-------------------|---------------------------------|
| Packing method    | Wooden pallet with wooden frame |
| Packed dimensions |                                 |
| Packed weight     | 260 kg                          |
| Weight            | 185 kg                          |

The displayed jerrycan is not part of standard delivery

|   |  |   |                    |      |
|---|--|---|--------------------|------|
| Title<br><b>Lay out DZW-1000-R</b>  |  | Customer  |                    |      |
| Article no.<br>83202200   | Drawing no.<br><b>1303004014</b>   | Drawn by<br>EvdH  |                    |      |
| <br><b>Elpress</b><br>Cleaning Systems | Handelstraat 21<br>NL - 5031 AV Boxmeer<br>The Netherlands<br>tel.: +31 (0)485 516969<br>fax.: +31 (0)485 514022<br>www.elpress.com        | Projection<br> | Date<br>17-10-2013 | Rev. |
|   | THIS DRAWING IS PROPERTY OF ELPRESS BV. IT IS A CONFIDENTIAL DOCUMENT AND MAY NOT BE COPIED, USED OR PUBLISHED WITHOUT WRITTEN PERMISSION. |   |                    |      |