

Top view

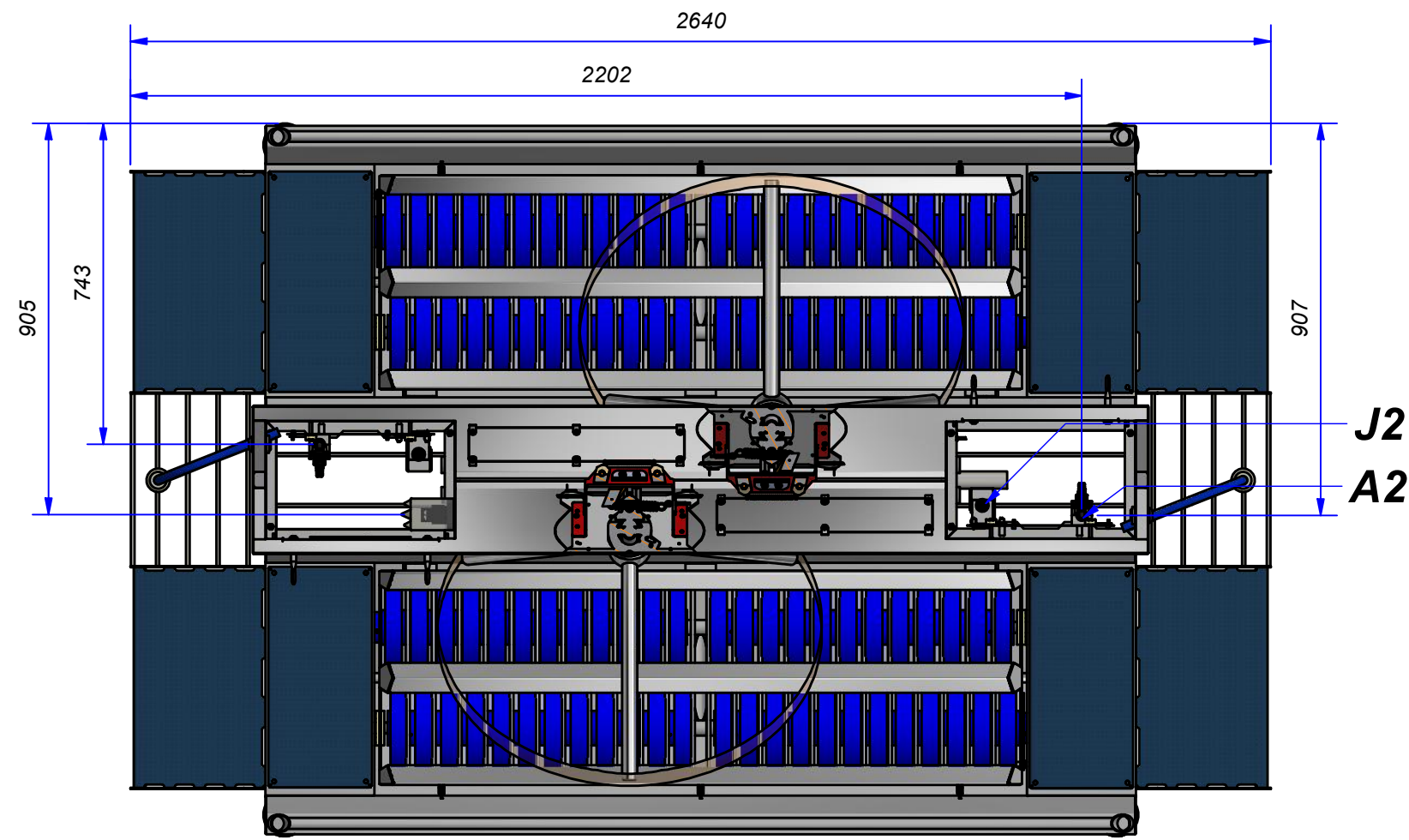

A-A (1:15)

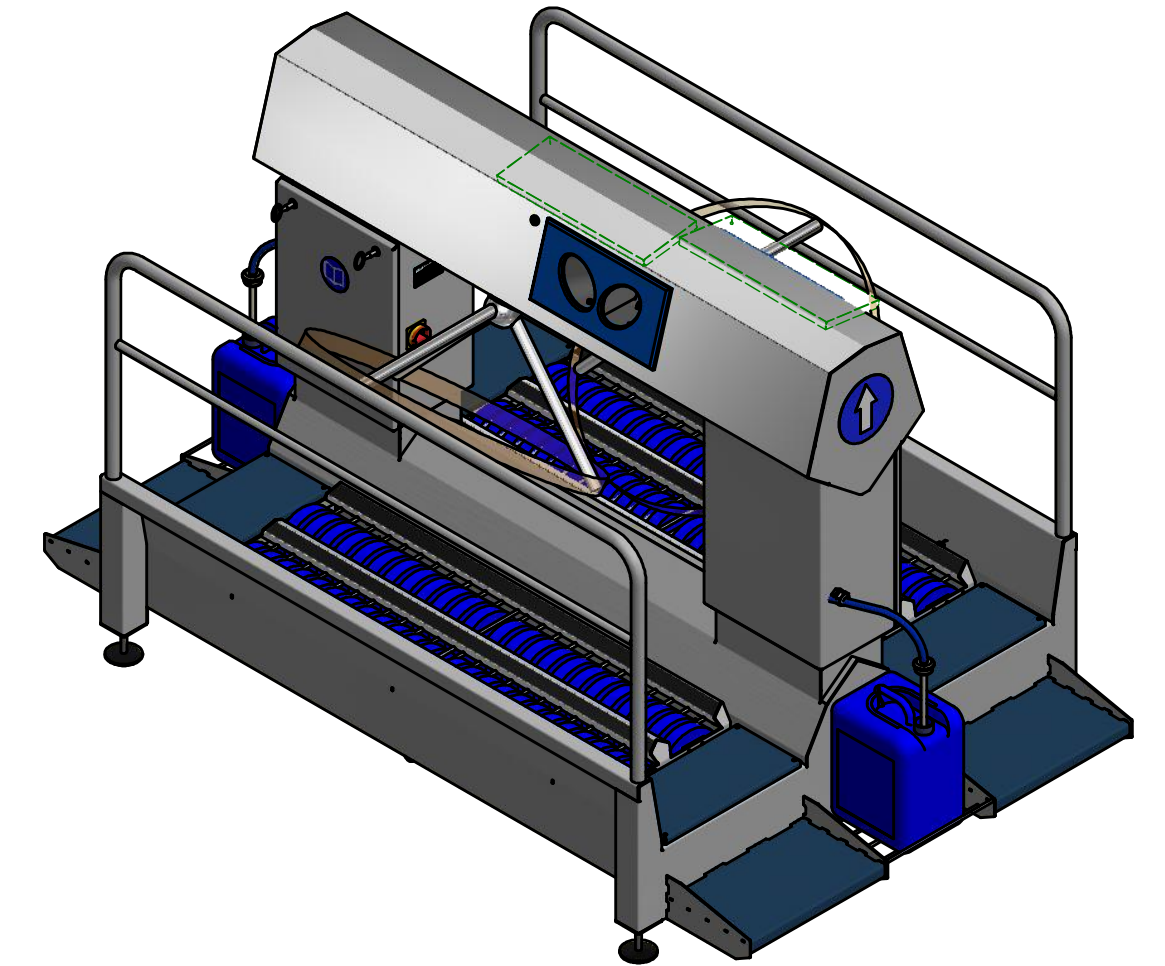

Green line: Optional Shelf

Connection values

A1	Water in	3/4" BSP Male
A2	Water in	3/4" BSP Male
D1	Drainage	Ø40 mm
D2	Drainage	Ø40 mm
D3	Drainage	Ø40 mm
F1	Chemical in	
F2	Chemical in	
J1	Desinfection in	
J2	Desinfection in	
X	Electrics	400 V / 50 Hz (3 ph + E + 0)
	Total power	2 kW
	Security	16 A
	Simultaneous value	100 %
	Connection	CEE-shape electrical outlet (5-pole)

Transport details

Packing method	Wooden pallet with wooden frame
Packed dimensions	275x175x195 cm
Packed weight	540 kg
Weight	430 kg

The displayed jerrycan is not part of standard delivery

Min. operating pressure 2.5 bar.
 Max. operating pressure 4 bar.
 Recommended operating pressure 3 bar.

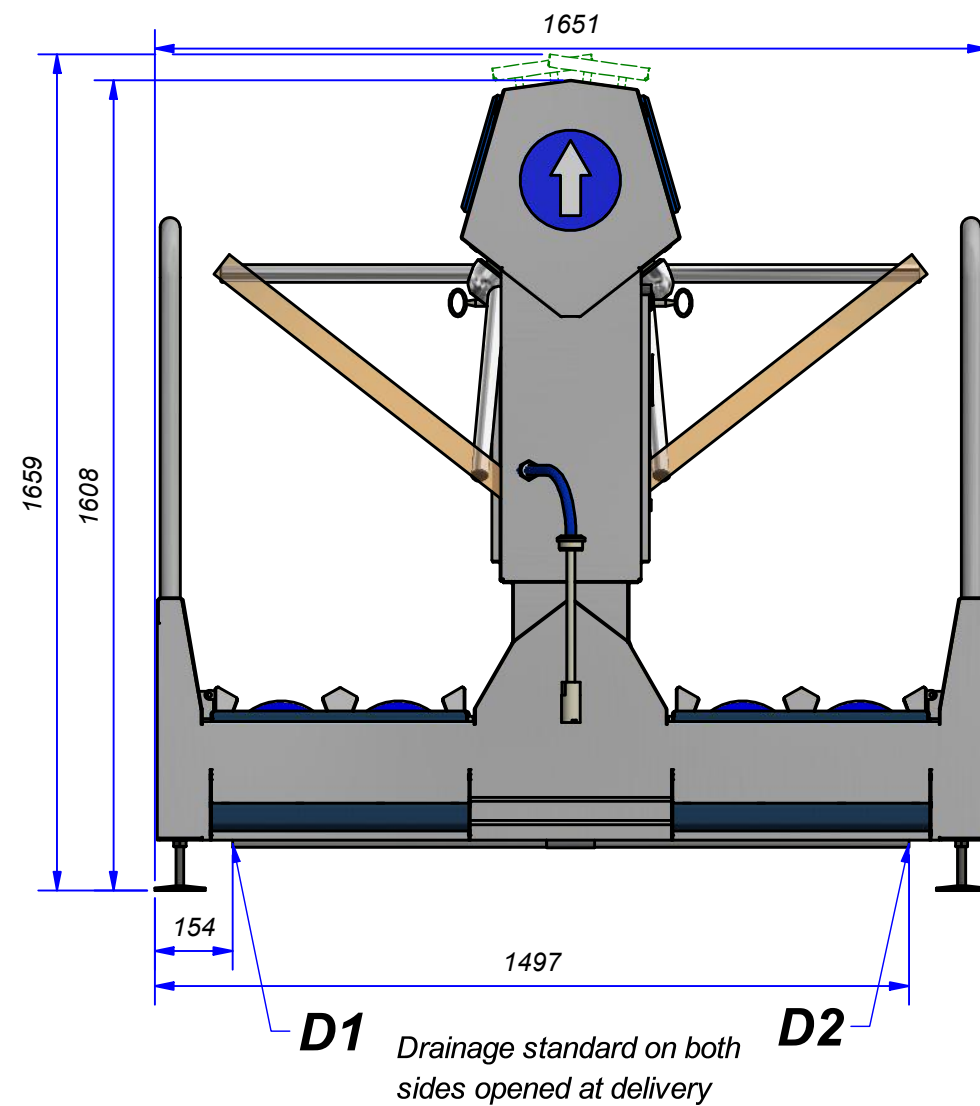

Side view

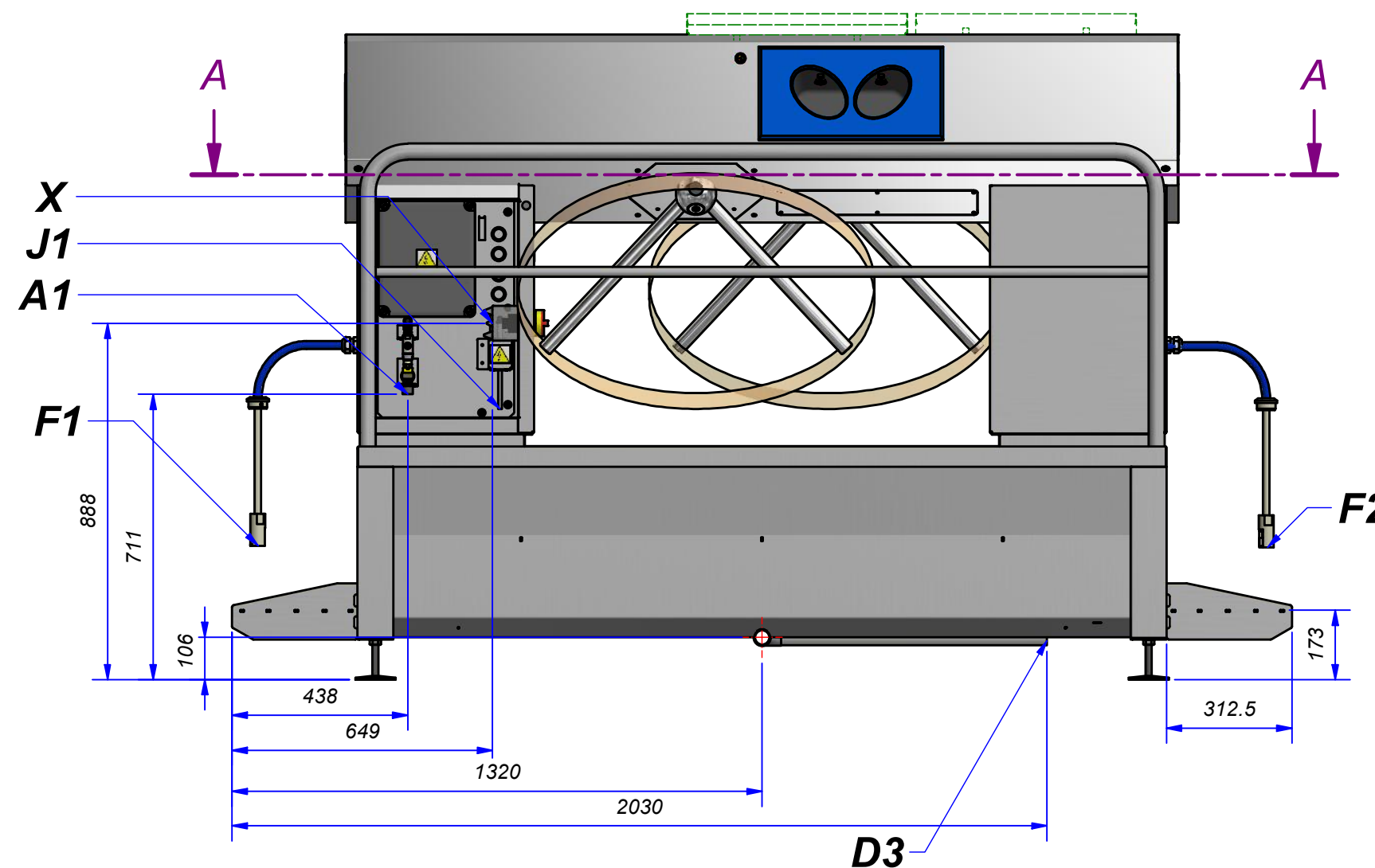

Front view

Drainage standard opened at delivery

Title Lay out COMBI-BB-DD-1500-R/L		Customer	
Article no. 83205300	Drawing no. 1303004071	Drawn by EvdH	
		Projection 	Date 6-11-2013
Handelstraat 21 NL - 5831 AV Boxmeer The Netherlands tel. : +31 (0)485 516969 fax.: +31 (0)485 514022 www.elpress.com		Rev. A	THIS DRAWING IS PROPERTY OF ELPRESS BV. IT IS A CONFIDENTIAL DOCUMENT AND MAY NOT COPIED, USED OR PUBLISHED WITHOUT WRITTEN PERMISSION.